

INSTALLATION TOOLING

HLH110

Hand Installation Tool For Small Collars

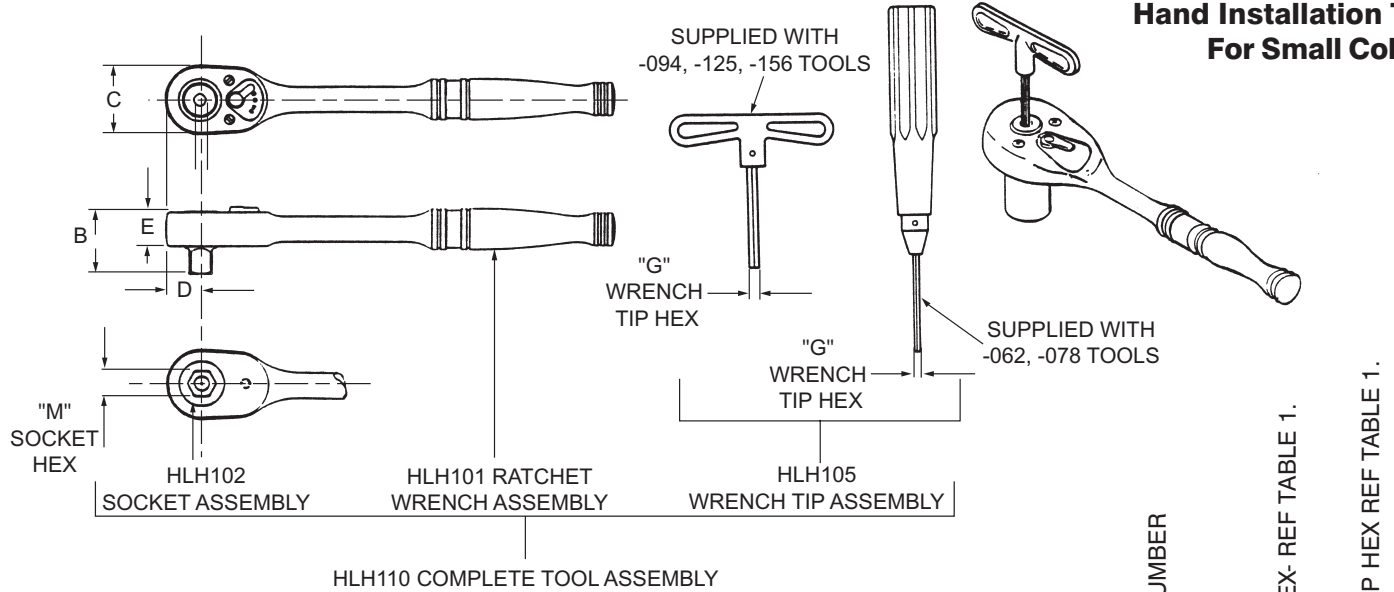

ORDERING INFORMATION

1. Determine collar driving hex and pin recess hex dimensions of the fasteners to be installed.
2. See Table 1 for "M" socket hex and "G" wrench tip hex combination to match collar driving hex and pin recess hex dimensions.

BASIC PART NUMBER

"M" SOCKET HEX- REF TABLE 1.

"G" WRENCH TIP HEX REF TABLE 1.

HLH110-250-078

TABLE 1

"M" SOCKET HEX (Matches Collar Driving Hex)	"G" WRENCH TIP HEX (Matches Pin Recess Hex)	COMPLETE TOOL ASSY. PART NO.	DIMENSIONS						SOCKET SQUARE DRIVE	RATCHET WRENCH ASSEMBLY PART NO.	SOCKET ASSEMBLY PART NO.	WRENCH TIP ASSEMBLY PART NO.
			A	B	C	D	E	F				
3/16	1/16	HLH110-187-062	5.0	1.187	1.0	0.500	0.312	0.156	1/4	HLH101/250	HLH102-187	HLH105-062
7/32		HLH102-218									HLH105-062	
1/4		HLH102-250									HLH105-062	
9/32		HLH102-281									HLH105-062	
5/16		HLH102-312									HLH105-062	
11/32	5/64	HLH110-343-062	5.0	1.187	1.0	0.500	0.312	0.156	1/4	HLH101/250	HLH102-343	HLH105-062
7/32		HLH102-218									HLH105-078	
1/4		HLH102-250									HLH105-078	
9/32		HLH102-281									HLH105-078	
5/16		HLH102-312									HLH105-078	
11/32		HLH102-343									HLH105-078	
3/8		HLH102-375									HLH105-078	
5/16		HLH102-312									HLH105-094	
11/32		HLH102-343									HLH105-094	
3/8		HLH102-375									HLH105-094	
7/16	3/32	HLH110-437-094	7.0	1.562	1.5	0.687	0.500	0.218	3/8	HLH101-375	HLH102-437	HLH105-094
1/2		HLH102-500									HLH105-094	
3/8		HLH102-375-A									HLH105-094	
7/16		HLH102-437									HLH105-125	
1/2		HLH102-500									HLH105-125	
7/16	5/32	HLH110-437-125	7.0	1.562	1.5	0.687	0.500	0.218	3/8	HLH101-375	HLH102-437	HLH105-156
1/2		HLH102-500									HLH105-156	

**HLH110
HAND INSTALLATION TOOL FOR SMALL COLLARS**



7001 rev —

INSTALLATION TOOLING

HLH149

Hand Installation Tool Double Box Ratchet Wrench

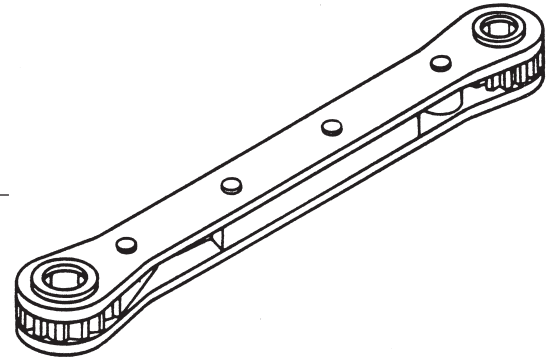
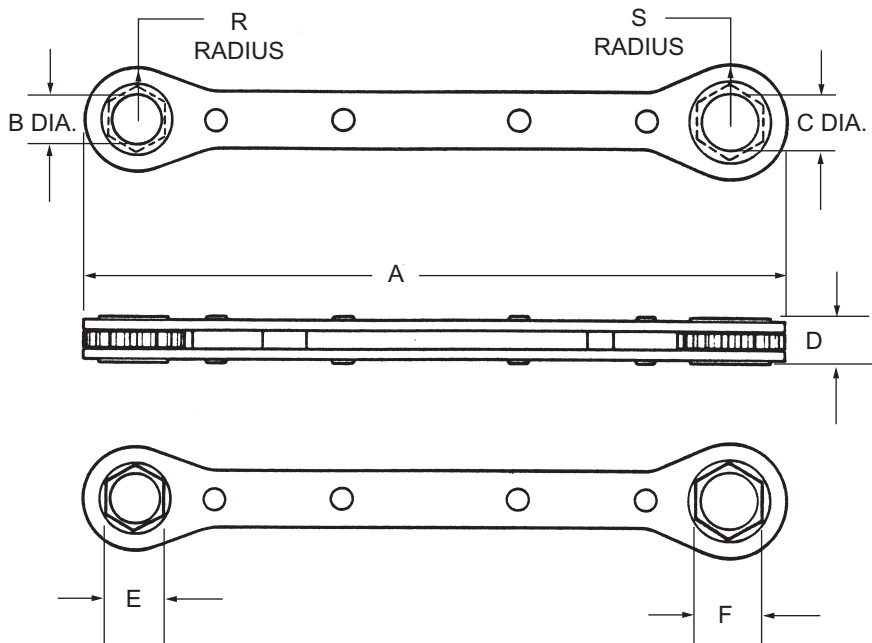

ORDERING INFORMATION

1. Determine collar driving hex dimensions of the fasteners to be installed.
2. See Table 1 for ("E" and "F") socket hexes to match collar driving hex. Determine Complete Tool Assembly Part Number.

BASIC PART NUMBER
"F" SOCKET HEX - REF TABLE 1
"E" SOCKET HEX - REF TABLE 1

HLH149-250-312

TABLE 1

SOCKET HEX PART NO.		COMPLETE TOOL ASSY. PART NO.	DIMENSIONS				RADIUS	
E	F		A	B	C	D	R	S
7/32	1/4	HLA149-218-250	4.25	0.171	0.171	0.38	0.280	0.312
1/4	9/32	HLH149-250-281						
1/4	5/16	HLH149-250-312						
9/32	5/16	HLH149-281-312						
5/16	11/32	HLH149-312-343	5.50	0.265	0.328	0.375	0.440	
5/16	3/8	HLH149-312-375		0.421	0.484			
7/16	1/2	HLH149-437-500						



INSTALLATION TOOLING

HLH150

Hand Installation Tool
High Strength Wrench Tip
For Small Collars

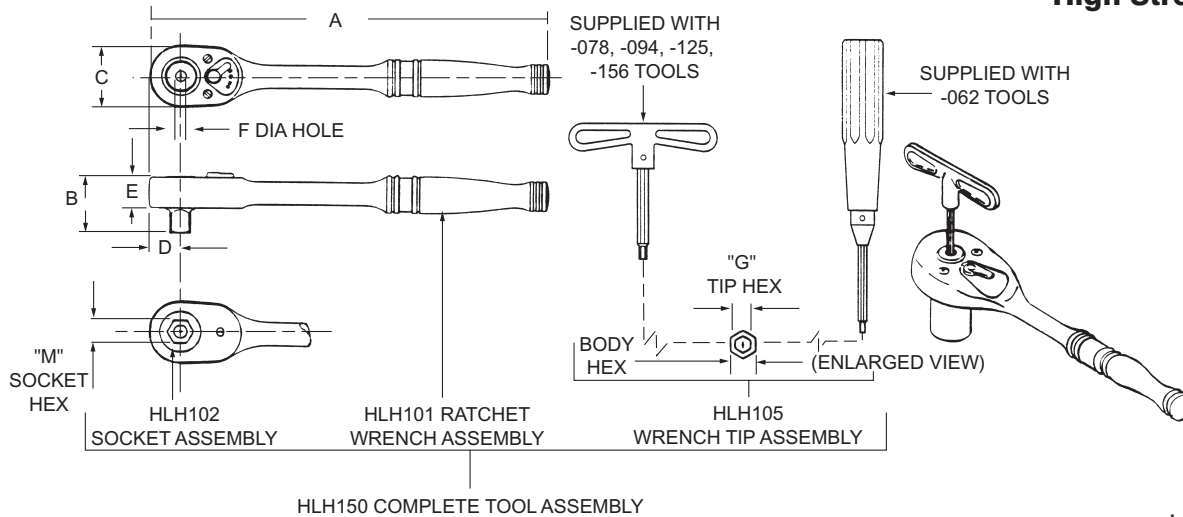

- ORDERING INFORMATION**
1. Determine collar driving hex and pin recess hex dimensions of the fasteners to be installed.
 2. See Table 1 for "M" socket hex and "G" wrench tip hex combination to match collar driving hex and pin recess hex dimensions.

BASIC PART NO. **HLH150-250-078**

"M" SOCKET HEX - REF TABLE 1

"G" WRENCH TIP HEX - REF TABLE 1

TABLE 1

"M" SOCKET HEX (Matches Collar Driving Hex)	"G" WRENCH TIP HEX (Matches Pin Recess Hex)	COMPLETE TOOL ASSY. PART NO.	DIMENSIONS						SOCKET SQUARE DRIVE	RATCHET WRENCH ASSY PART NO.	SOCKET ASSEMBLY PART NO.	WRENCH KEY ASSEMBLY PART NO.	KEY-HEX BODY HEX	KEY PART NO.
			A	B	C	D	E	F						
3/16	1/16	HLH150-187-062								HLH102-187	HLH105-062T STRAIGHT HANDLE	.062 .078	HLH202-078	
7/32		HLH102-218												
1/4		HLH102-250												
9/32		HLH102-281												
5/16		HLH102-312												
11/32		HLH102-343												
7/32	5/64	HLH150-218-078	5.0	1.187	1.0	.500	.312	.156	1/4	HLH101-250	HLH102-218	HLH105-078T T-HANDLE	.078 .094	HLH202-094
1/4		HLH102-250												
9/32		HLH102-281												
5/16		HLH102-312												
11/32		HLH102-343												
3/8		HLH102-375												
5/16	3/32	HLH150-312-094								HLH102-312	HLH105-078T T-HANDLE	.078 .094	HLH202.125	
11/32		HLH102-343												
3/8		HLH102-375												
7/16		HLH102-437												
1/2		HLH102-500												
3/8		HLH102-375-A												
7/16	1/8	HLH150-437-125	7.0	1.562	1.5	.687	.500	.218	3/8	HLH101-375	HLH102-437	HLH105-125T T-HANDLE	.125 .156	HLH202-156
1/2		HLH102-500												
7/16		HLH102-437												
1/2	5/32	HLH150-437-156								HLH102-437	HLH105-156T T-HANDLE	.156 .187	HLH202-187	
1/2		HLH102-500												

**HLH150
HAND INSTALLATION TOOL HIGH STRENGTH WRENCH TIP FOR SMALL COLLARS**



7003 rev —

INSTALLATION TOOLING

HLH213

Assembly, Hand Installation Tool Double Hex L-Key

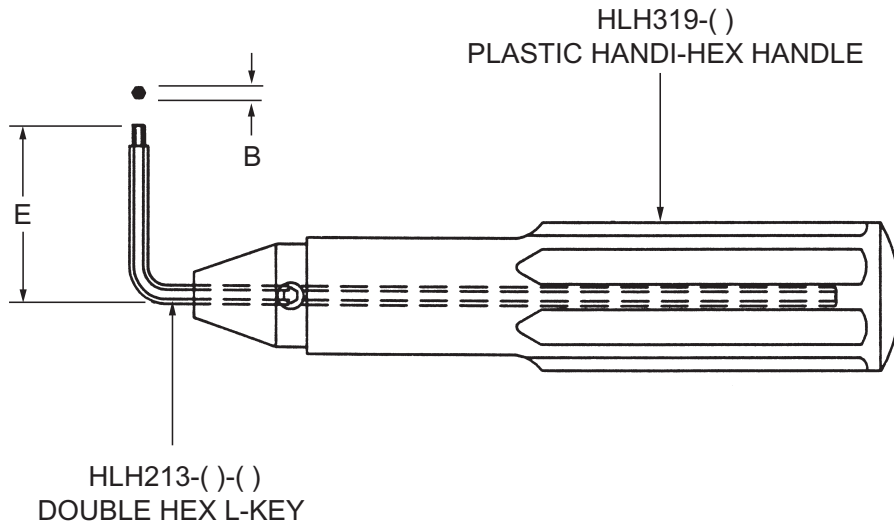

BASIC PART NUMBER

"E" - REF TABLE 1

"B" - REF TABLE 1

HLH213-1-062

Example 1: complete socket
assy. part no.

ORDERING INFORMATION

1. Determine broach hex dimensions of the pins to be installed.
2. See Table 1 for ("B" and "E") dimensions to match broached hex and required reach.
3. Determine Complete Tool Assembly Part Number. See example 1.

TABLE 1

COMPLETE TOOL ASSEMBLY PART NO.	B	E	PLASTIC HANDI-HEX HANDLE	HIGH-STRENGTH HEX KEY PART NO.
HLH213-1-062	1/16	5/8	HLH319-078	HLH212-1-062
HLH213-1-078	5/64		HLH319-094	HLH212-1-078
HLH213-1-094	3/32		HLH319-125	HLH212-1-094
HLH213-1-125	1/8		NOT AVAILABLE	HLH212-1-125
HLH213-1-156	5/32		NOT AVAILABLE	HLH212-1-156
HLH213-2-062	1/16	1-5/8	HLH319-078	HLH212-2-062
HLH213-2-078	5/64		HLH-319-094	HLH212-2-078
HLH213-2-094	3/32		HLH-319-125	HLH212-2-094
HLH213-2-125	1/8		NOT AVAILABLE	HLH212-2-125
HLH213-2-156	1/16		NOT AVAILABLE	HLH212-2-156

**HLH213
ASSEMBLY, HAND INSTALLATION TOOL DOUBLE HEX L-KEY**



7004 rev —

INSTALLATION TOOLING HLH216

Hand Installation Tool Offset Ratchet Wrench

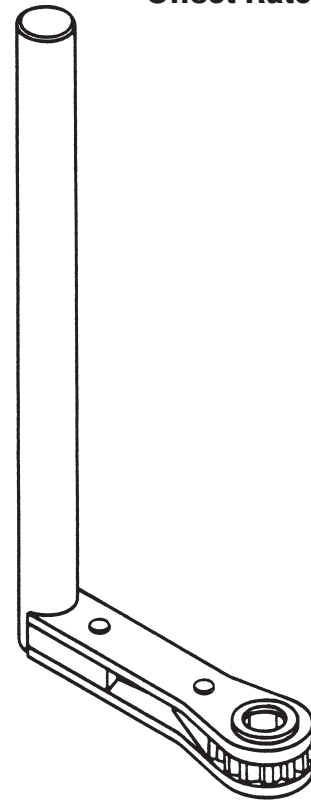

BASIC PART NUMBER

"M" SOCKET HEX - REF TABLE 1

HLH216-312

ORDERING INFORMATION

1. Determine collar driving hex and pin recess hex dimensions of the fasteners to be installed.
2. See Table 1 for "M" socket hex to match collar driving hex and pin recess hex dimensions.
3. Determine Complete Tool Assembly Part Number. See example 1.

TABLE 1

"M" SOCKET HEX (Matches Collar Driving Hex)	COMPLETE TOOL ASSY. PART NO.	DIMENSIONS		
		A	B	C
7/32	HLA216-218	0.312	2.37	0.280
1/4	HLH216-250			
9/32	HLH216-281			
5/16	HLH216-312			
11/32	HLH216-343			
3/8	HLH216-375	0.375	2.95	0.440
7/16	HLH216-437			
1/2	HLH216-500			

INSTALLATION TOOLING

HLH311

Hand Installation Tool With Minimum Edge Distance

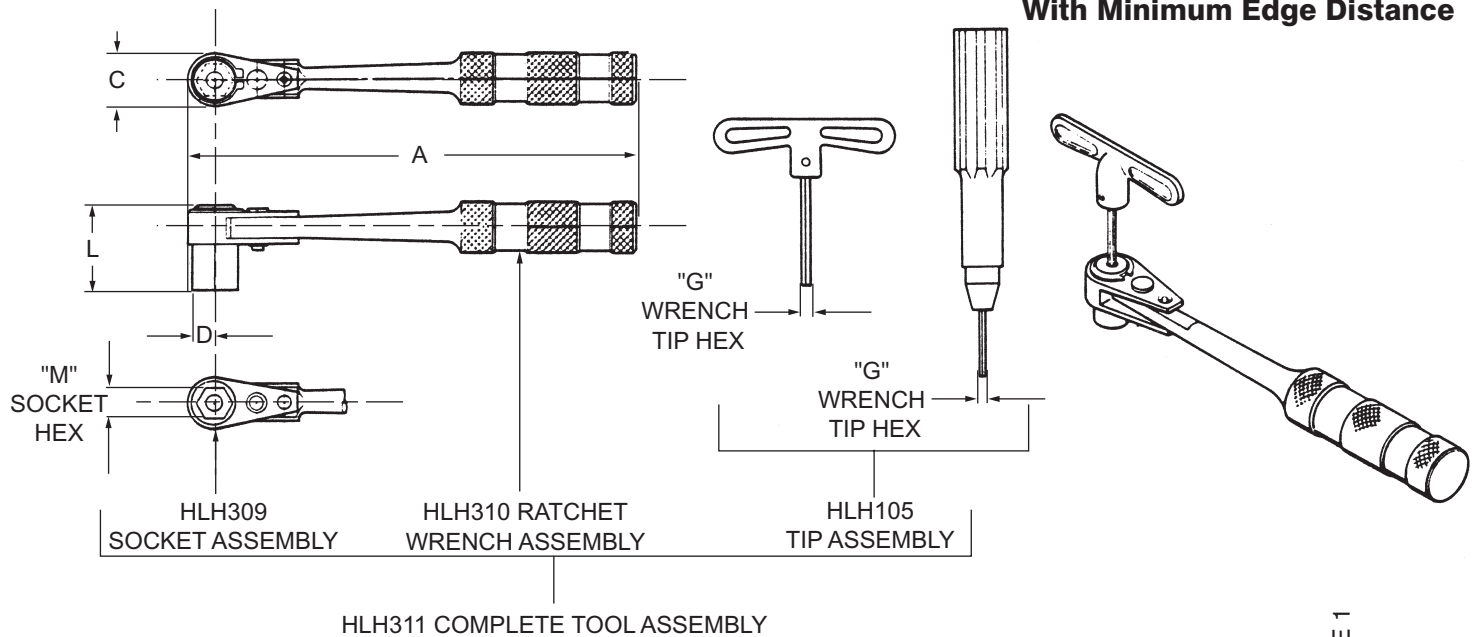

CODE	L EXTENDED SOCKET
E	0.750
G	0.875
H	1.375
C	1.500
F	1.750

ORDERING INFORMATION

1. Determine collar driving hex and pin recess hex dimensions of the fasteners to be installed.
2. See Table 1 for "M" socket hex and "G" wrench tip hex combination to match collar driving hex and pin recess hex dimensions.
3. See Table 2 for "L" extended socket length.

BASIC PART NUMBER

 "M" SOCKET HEX - REF TABLE 1

 "G" WRENCH TIP HEX - REF TABLE 1
HLH311-437E-094

TABLE 1

"M" SOCKET HEX (Matches Collar Driving Hex)	"G" WRENCH TIP HEX (Matches Pin Recess Hex)	COMPLETE TOOL ASSY. PART NO.	DIMENSIONS				RATCHET WRENCH ASSY PART NO.	SOCKET ASSEMBLY PART NO.	WRENCH KEY ASSEMBLY PART NO.								
			A	L	C	D											
1/4	5/64	HLH311-250E-078	6.40	0.750	0.562	0.281	HLH310-1	HLH309-250E	HLH105-078								
		HLH311-250F-078		1.75			HLH310-1	HLH309-250F	HLH105-078								
HLH311-312E-078		0.750		HLH310-1			HLH309-312E	HLH105-078									
HLH311-312H-078		1.375		HLH310-1			HLH309-312H	HLH105-078									
HLH311-343E-078		0.750		HLH310-1			HLH309-343E	HLH105-078									
HLH311-343E-094		0.750		HLH310-1			HLH309-343E	HLH105-094									
11/32	3/32	HLH311-343H-094	6.60	1.375	0.750	0.375	HLH310-1	HLH309-343H	HLH105-094								
		HLH311-437E-094		0.750			HLH310-1	HLH309-437E	HLH105-094								
		HLH311-437G-094		0.875			HLH310-2		HLH105-094								
HLH311-437C-094		1.500		HLH310-2				HLH105-094									
HLH311-437F-094		1.750		HLH310-2				HLH105-094									
7/16		1/8		HLH311-437E-125			6.60	0.750	0.750	0.375	HLH310-2		HLH105-125				
				HLH311-500G-156				0.875			HLH310-2		HLH105-156				
1/2				5/32				HLH311-500G-156			6.60	0.875	0.750	0.375	HLH310-2		HLH105-156
								HLH311-500G-156				0.875			HLH310-2		HLH105-156

**HLH311
HAND INSTALLATION TOOL WITH MINIMUM EDGE DISTANCE**



INSTALLATION TOOLING

HLH500

Hand Installation Tool
For Large Size Collars

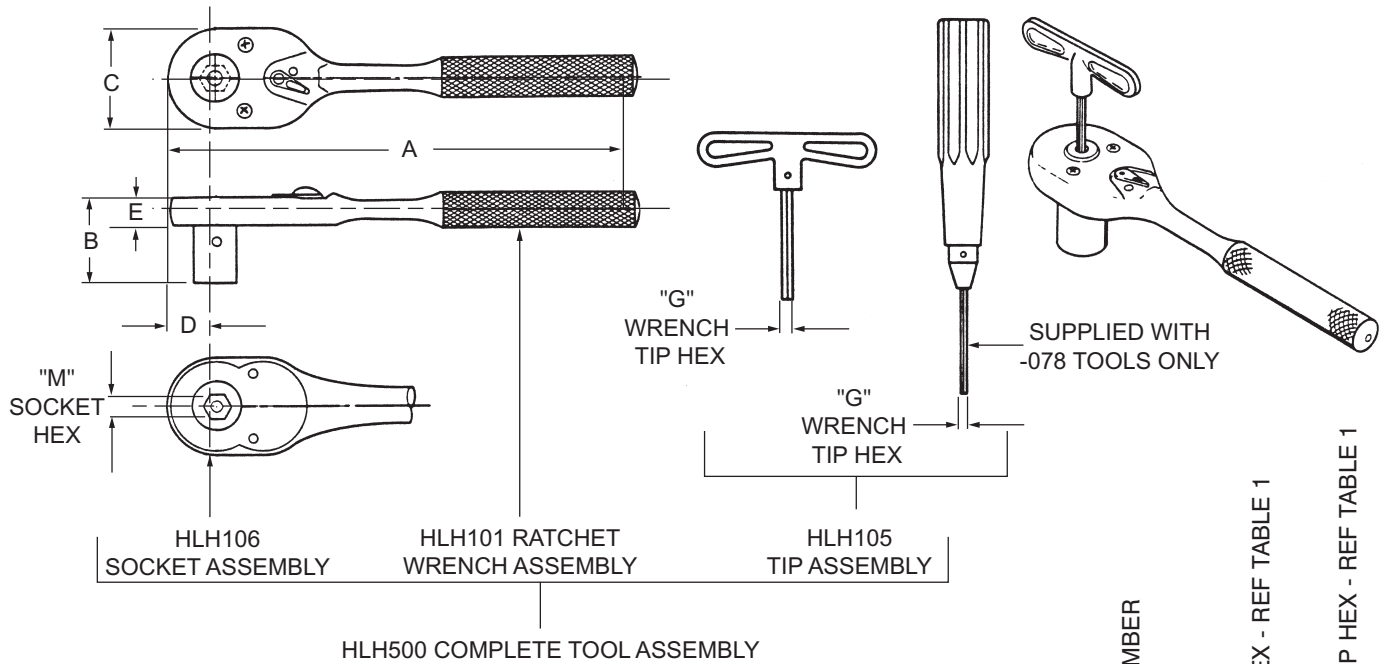

ORDERING INFORMATION

1. Determine collar driving hex and pin recess hex dimensions of the fasteners to be installed.
2. See Table 1 for "M" socket hex and "G" wrench tip hex combination to match collar driving hex and pin recess hex dimensions.
3. Determine Complete Tool Assembly Part Number. See example 1.

HLH500-625-156

TABLE 1

"M" SOCKET HEX (Matches Collar Driving Hex)	"G" WRENCH TIP HEX (Matches Pin Recess Hex)	COMPLETE TOOL ASSY. PART NO.	DIMENSIONS					SOCKET SQUARE DRIVE	RATCHET WRENCH ASSEMBLY PART NO.	SOCKET ASSEMBLY PART NO.	WRENCH TIP ASSEMBLY PART NO.
			A	B	C	D	E				
3/8	5/64	HLH500-375-078	7.0	1.437	1.375	0.687	0.500	3/8	HLH101-375	HLH106-375	HLH105-078
1/2	3/32	HLH500-500-094		1.500						HLH106-500	HLH105-094
1/2	1/8	HLH500-500-125		HLH106-500						HLH105-125	
9/16	1/8	HLH500-500-125	10.0	2.187	1.750	0.875	0.687	1/2	HLH101-500	HLH106-562	HLH105-125
9/16	5/32	HLH500-562-125								HLH106-562	HLH105-156
9/16	3/16	HLH500-562-156								HLH106-562	HLH105-187
5/8	5/32	HLH500-562-187								HLH106-625	HLH105-156
11/16	5/32	HLH500-625-156								HLH106-687	HLH105-156
11/16	7/32	HLH500-687-156								HLH106-687	HLH105-156
3/4	3/16	HLH500-750-187								HLH106-750	HLH105-218
7/8	7/32	HLH500-875-218	2.437	HLH106-875	HLH105-187						
15/16	1/4	HLH500-937-250	20.0	3.125	2.625	1.250	1.125	3/4	HLH101-750	HLH106-937	HLH105-250
1	1/4	HLH500-1000-250								HLH106-1000	HLH105-250
1-1/8	5/16	HLH500-1125-312								3.437	HLH106-1125

**HLH500
HAND INSTALLATION TOOL FOR LARGE SIZE COLLARS**

